



# MEP Hire

Mechanical, Electrical & Low Level Access Specialists

0800 587 5121

e: [hire@mephire.co.uk](mailto:hire@mephire.co.uk)  
[www.mephire.co.uk](http://www.mephire.co.uk)

# BRIDGE QUICK

SINGLE WIDTH SQAGR





# MEP Hire

Mechanical, Electrical & Low Level Access Specialists

0800 587 5121

e: [hire@mephire.co.uk](mailto:hire@mephire.co.uk)  
[www.mephire.co.uk](http://www.mephire.co.uk)

## CONTENTS

CONTENTS	1	BRIDGE QUICK 4.2m x 2.5m SW - ASSEMBLY	12
INTRODUCTION	2	10 POINT PRE-USE SAFETY CHECKLIST	14
KNOW YOUR BRIDGE QUICK	3	REGISTRATIONS	15
KNOW YOUR BRIDGE QUICK'S COMPONENTS	4		
KNOW YOUR KIT LIST AND SPECIFICATIONS	7		
SAFETY DOS AND DON'TS - ALWAYS	8		
SAFETY DOS AND DON'TS - NEVER	9		
BEFORE YOU START	10		
GETTING STARTED	11		

# INTRODUCTION

BRIDGE QUICK is a versatile and high quality mobile access bridged tower system providing a large working platform area. Ideal for maintenance and installation work or short term access. It is designed in accordance with the latest testing and quality standards. The EIGERTOWER components comply with BS EN 1004 -1 : 2020 and the bridging components have been designed and tested in accordance with BS 1139 : 2022. The resulting structure complies with WAHR. The structure has vertical ladder access and designed for Class 3 loadings.

Platform heights between 1.7m & 4.7m internal / external. Tower designation is EN1004-3-2/12-XXXD-H2.

This instruction manual is in compliance with BS EN 1004-2-en.

Verification and assessment documentation is held by POP UP Products Ltd.

Our priority is to help ensure the safe operation of our products, so please pay particular attention to the safety tips on pages 8 & 9.

We want you to enjoy the safe and responsible use of BRIDGE QUICK with the minimum of fuss and this guide is designed to get you up and running as quickly and as safely as possible.

We recommend that you read this guide prior to assembling and using your BRIDGE QUICK.

This instruction manual shall be available on the location of use of your BRIDGE QUICK.

Your BRIDGE QUICK shall only be used in accordance with this assembly guide without modification and national regulations.

User training courses cannot be a substitute for instruction manuals but only complement them.

This product shall only be used according to the instruction manual.

Only original Pop Up Products BRIDGE QUICK components, in undamaged condition as specified in this instruction manual, shall be used to assemble this access structure.

Pop Up Products Limited cannot accept responsibility in the event of an accident occurring because of mixing components from different manufacturers.

Mobile access structures and working towers designed in accordance with EN 1004-1 and BS 1139 are not anchor points for personal fall arrest equipment.

Working is only permitted on a platform with complete side protection, including guardrails and toeboards.

Maximum uniformly distributed load permitted on the completed structure is 750Kg, ensuring the hatch areas are always kept clear of materials to allow unimpeded access to the platform. The maximum number of persons permitted on the working platform at any one time should never exceed the maximum UDL. This includes tools and materials. As a guide each tower platform can be evenly loaded to a maximum of 250kg and the bridging section evenly loaded to a maximum of 250kg.

# KNOW YOUR BRIDGE QUICK

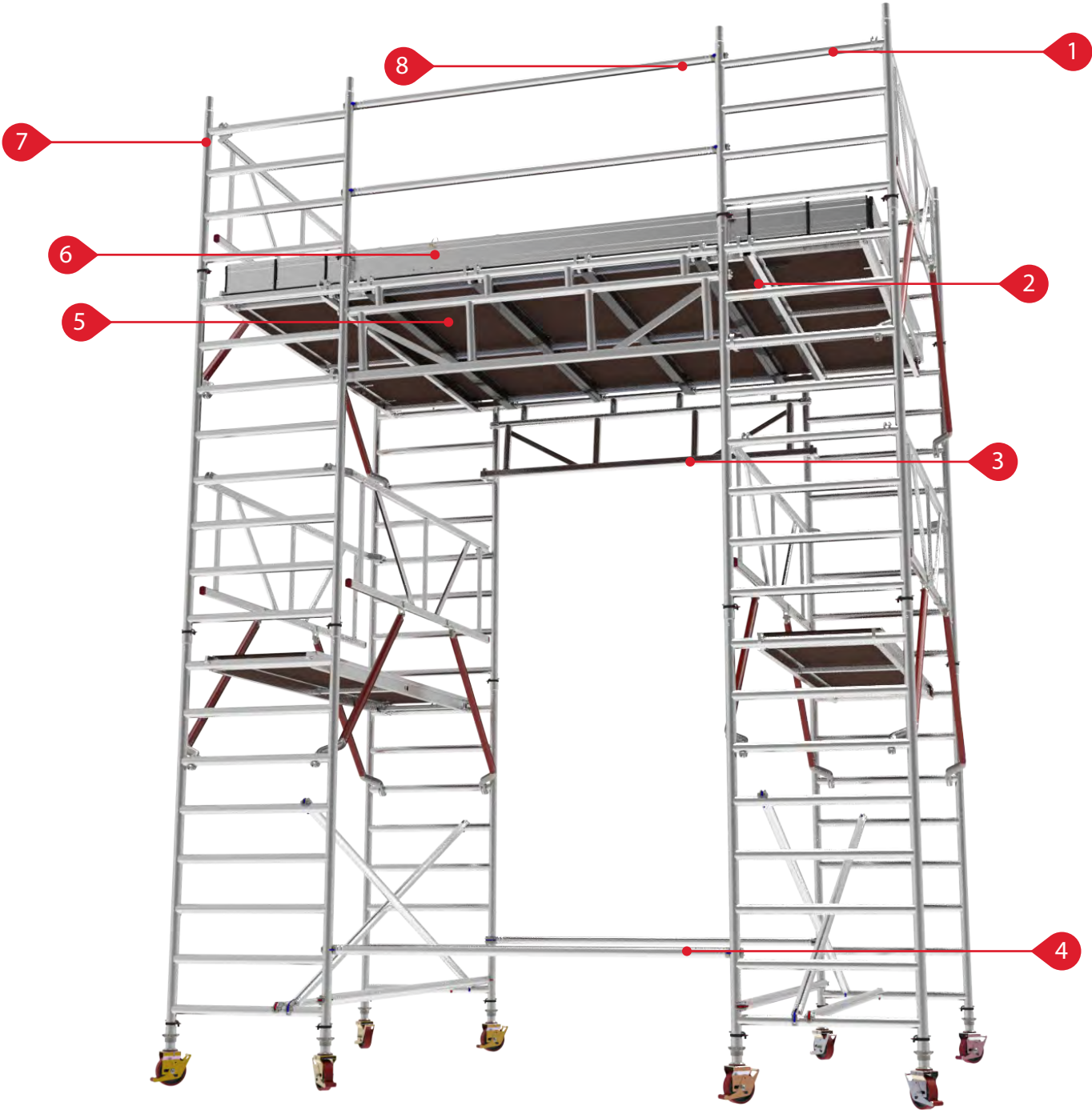

## PARTS LISTING

- |   |                 |   |                               |
|---|-----------------|---|-------------------------------|
| 1 | FIRST TOWER     | 5 | FIBER-DECK® BRIDGING PLATFORM |
| 2 | INFILL PLATFORM | 6 | TOEBOARD                      |
| 3 | BRIDGING BEAM   | 7 | SECOND TOWER                  |
| 4 | LINK BRACE      | 8 | LINK BRACE (UPPER)            |

# KNOW YOUR EIGERTOWER / BRIDGE QUICK COMPONENTS

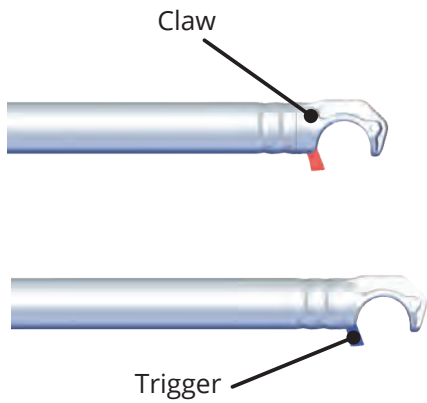

## 1 BRACES

Both horizontal and diagonal braces are fitted with triggered hooks at both ends. The triggers, when operated, pull back to allow the hook to be placed over the tubing used on the tower. Horizontal braces are also used as guardrails. All brace hooks (Except the first base assembly braces) must be attached to the top of the frame horizontal tube. Always double check that each hook is positively locked onto the tubing before using the tower. The brace hook trigger mechanisms are colour coded to show which are the horizontal (Red) and which are the diagonal (Blue) braces.

## 2 FRAME CLIPS

The frame clip's pin locates into a retaining hole in the frames to lock tower sections together when placed one on top of the other. The pin is locked in place by a red tab to ensure that it remains in place. From the disengaged position, pivot the pin / tab to bring the pin horizontal. Insert the pin fully through the retaining hole with its tail pointing down. Next flip the tab vertically to lock the pin in place. Removal is simply a reversal of the fitting sequence.

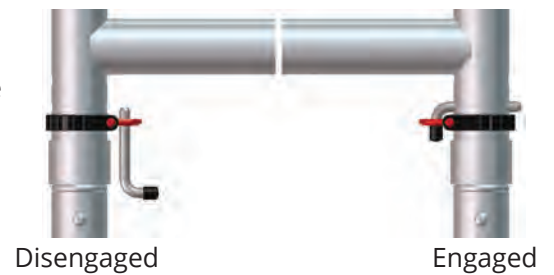

## 3 STABILISER COUPLER CLAMP

The coupler clamps are used to secure the stabilisers to the tower's vertical tubing. With the clamp jaw open, offer it to the tube. Bring the jaw around the tube and set the buckle on to the hook, then close the clamp arm to lock the stabiliser in position. A similar clamp is fitted to the stabiliser extension leg.

## 4 WIND-LOCK CATCH

The wind lock catches comprise of a set of auto-engaging hooks at one end of the platform and a single gravity type catch at the other. The purpose of these devices is to prevent up-lift of the platforms in windy conditions. To engage the auto wind lock (AWL) simply tilt the platform at the angle shown before placing the hooks onto the rung of the end frame. Lower the opposite end of the platform onto the opposite end frame rung and the gravity type lock will automatically engage. Simply lift and hold the gravity lock before tilting the platform to dis-engage the opposite AWL hooks when removing the platform on tower disassembly.

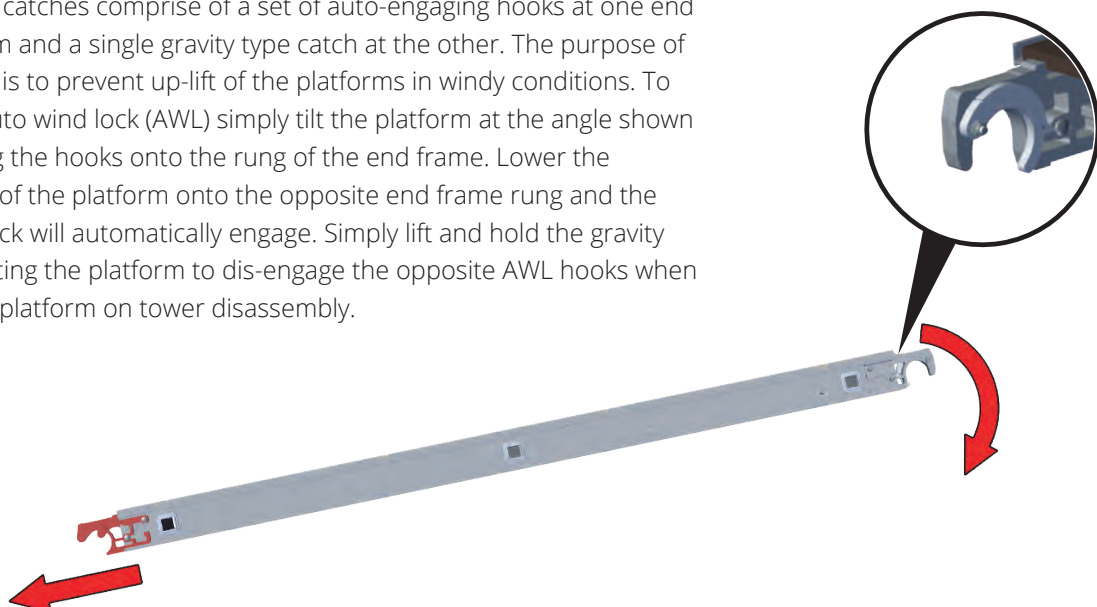

# KNOW YOUR EIGERTOWER / BRIDGE QUICK COMPONENTS

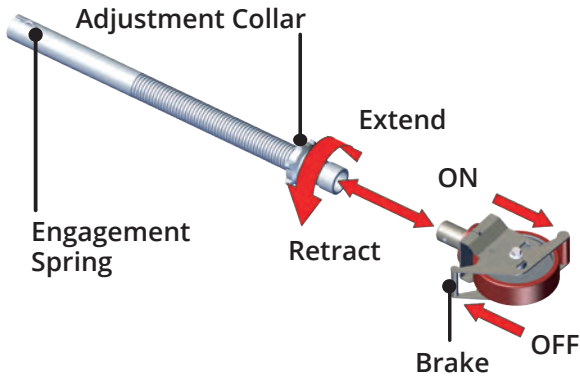

## 7 ADJUSTABLE LEG AND CASTOR

The adjustable leg and castor allows for accurate positioning of your EIGERTOWER in relation to your workplace. The leg can be extended or retracted to allow for levelling and the brake must be applied to prevent movement.

Do not use the adjustable legs of the wheels to increase the height of the tower. Only use the adjustable legs to level the tower. Make sure that the distance from the ground to the first step does not exceed 400 mm.

## 8 TOEBOARD

The toeboard, when placed on the working platform, prevents materials and tools from falling from the tower. It consists of two separate sections consisting of folding side and end sections which are articulated via a series of hinges.

It can be opened and fitted over the platform edges by first unfolding the ends and sides as shown in the image to the left and connecting the two sections together using the locking pins.

Once unfolded, place all four lower inside edges over the outer edges of the platform.

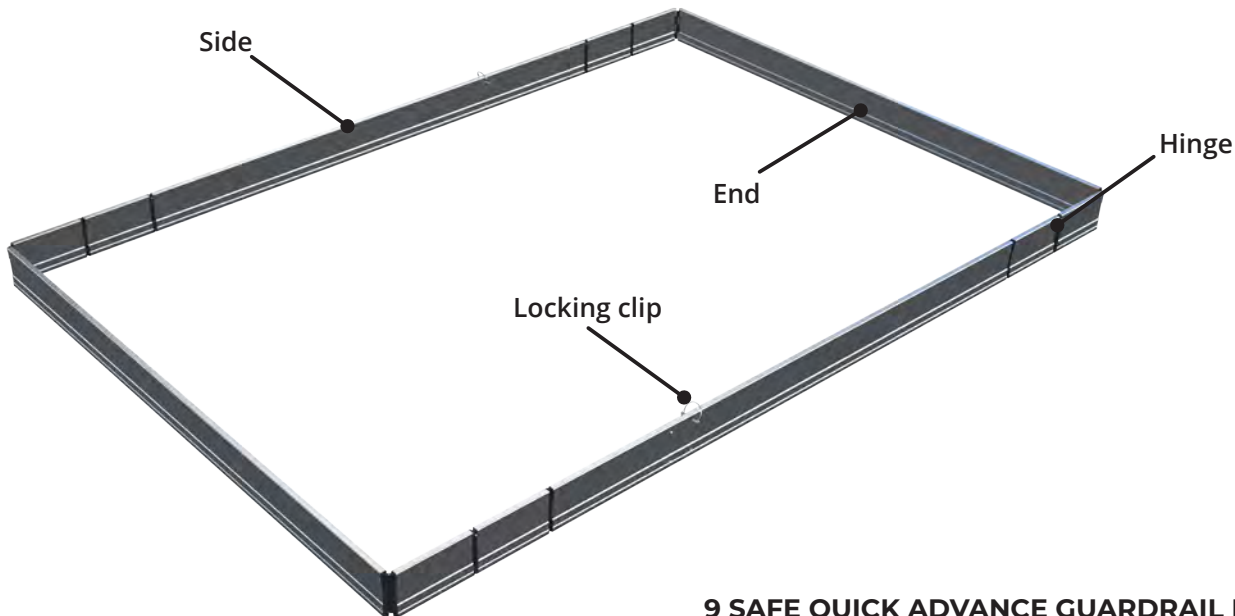

## 9 SAFE QUICK ADVANCE GUARDRAIL PANELS (SQ AGR)

The SQ AGR panels consist of both horizontal bracing and diagonal bracing members in a panel which can be attached to the tower from a safe guarded position. The horizontal bracing elements within the panel also act as a set of 'integral' guardrails and as such provides automatic guarding in advance to accessing the next level or lift of tower.

The panels are attached by means of the same type of triggered hook as the horizontal and diagonal braces. The triggered hooks are found at the end of the arms at the base of the panel and another pair of hooks can be found at the top of the panel. However these hooks are not triggered and are simply placed over the horizontal frame tubes. They have rubber inserts placed in the hooks to prevent the panels from slipping on the horizontal tubes.

The triggered hooks at the base are used to positively lock the panel in position. Place the upper hooks over the horizontal frame tube 2m above the assembly platform and then 'snap' the triggered hooks onto the lower horizontal frame tubes.

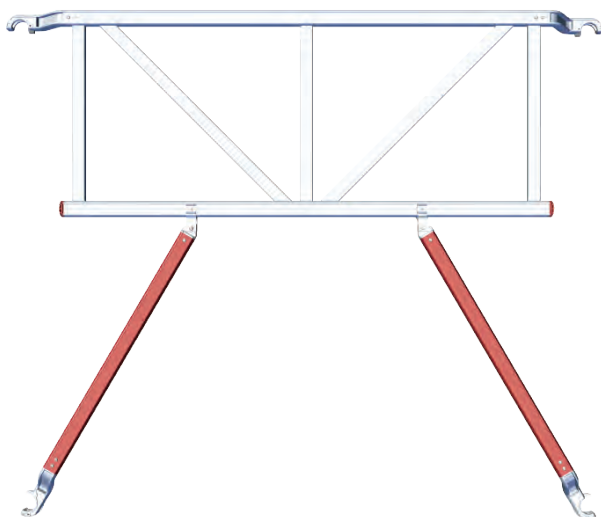

# KNOW YOUR EIGERTOWER / BRIDGE QUICK COMPONENTS

## 10 BRIDGING BEAM

The bridging beam is a lattice beam that connects the two access towers together and provide support for the bridging platforms. The lower hooks should be placed three rungs below the platform height and tilted in towards the centre of the towers. The beam should then be tilted towards the outside of the towers and the upper hooks engaged and locked.

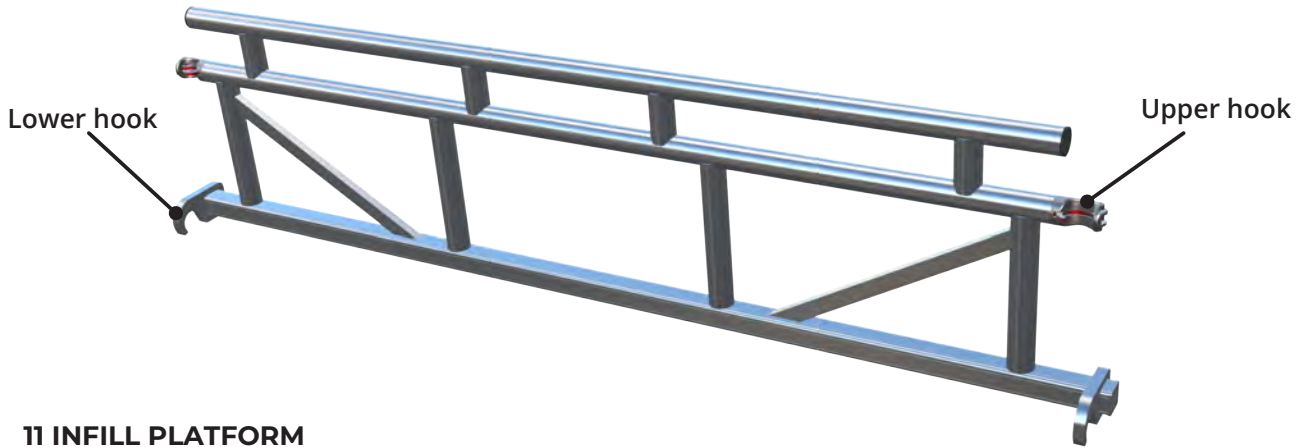

## 11 INFILL PLATFORM

The infill platform is a narrow platform that closes the gap between the interlinking platforms and the two towers. A cut out is provided to enable correct placing of the platform. The platform also features two gravity wind locks unlike the standard platform which have a set of AWL hooks on one end and a single gravity wind lock on the other.

The bridging platforms also have gravity wind locks at both ends of the platform and both the bridging and infill platforms can be distinguished by having black side bearers, unlike the standard tower platforms which have red side bearers.

Place the non cut out end of the platform between the tower and the bridging beam with the edge of the infill platform butted up against the tower platform, slowly lower the other end of the infill platform, ensuring the cut out is central to the tower end frame vertical tube. Once lowered fully check all wind locks have engaged correctly.



## INSPECTION, CARE & MAINTENANCE

Keep all components clean and free from contaminants. If any part becomes contaminated with paint, acid, oils or similar products the tower must not be used until the effected components have been cleaned and re-inspected.

Particular attention should be paid to welded joints and any moving parts, such as brace claws, adjustable leg adjustment collars and stabiliser clamps. Ensure all safety decals are present, intact and readable.

A detailed Inspection Guide is available. To obtain a copy of this guide, please contact POP UP Products. Threads, hinges and brace claws may be lubricated with light oil to ensure correct functionality is maintained. Ensure oil does not contaminate climbing or walking surfaces.

All components should be stored in a dry location where they will be protected from adverse weather conditions. When storing or transporting, keep frames upright and platforms flat. Do not stack excessively to avoid stress damage. Please contact POP UP Products for further details on maintenance and repair of your components.

# KNOW YOUR KIT LIST AND SPECIFICATIONS

## COMPONENT MATRIX AND WEIGHTS UTILISING 2.5m SINGLE WIDTH (850mm) TOWERS

### WORKING AREA DIMENSIONS - 2.4m x 3.5m

WH = Working Height  
PH = Platform Height

COMPONENT SCHEDULE			EXTERNAL / INTERNAL USE					
			BQSS37/25	BQSS42/25	BQSS47/25	BQSS57/25	BQSS62/25	BQSS67/25
NI CODE	DESCRIPTION	UNIT WEIGHT 2.5M (kg)	3.7 WH 1.7 PH	4.2 2.2	4.7 2.7	5.7 3.7	6.2 4.2	6.7 4.7
PBCT6	Castor	3.26	8	8	8	8	8	8
PBALS	Adjustable Leg	1.42	8	8	8	8	8	8
PBRS4-250	4 Rung end frame	4.04	4	4	0	4	4	0
PBRS6-250	6 Rung end frame	5.84	4	0	4	4	0	4
PBRS8-250	8 Rung end frame	7.63	0	4	4	4	8	8
PBTP2	Hatch Platform	18.00	2	2	4	4	4	6
PBGRA25025	Safe Quick AGR Panel	8.77	4	4	4	8	8	8
PBDB25	Horizontal Brace	2.22	8	8	8	8	8	8
PBDB27	Diagonal Brace	2.32	4	4	4	4	4	4
PBST2	Telescopic Stabiliser	6.44	0	0	8	8	8	8
BQBU18	Bridging Beam	11.00	2	2	2	2	2	2
BQID25	Infill Platform	12.00	2	2	2	2	2	2
BQFD25	Bridging Platform	13.00	3	3	3	3	3	3
BQTS25	Toeboard Set	19.00	1	1	1	1	1	1
PBDB21	Bridging Handrail Brace	1.90	6	6	6	6	6	6
Remove Stabilisers after build (Y/N)			N/A	N/A	Y	Y	Y	N
Total structure weight (kg)			291	298	393	444	451	494
Point loading per castor @ UDL 750kg			242	243	261	271	272	280

#### Notes:

Total structure weight is rounded up to nearest kilogram  
The component matrix includes all components from first and second towers.

Platform heights 1.7 and 2.2m can be assembled from the ground and therefore do not require stabilisers to be used during the construction of the first and second towers or the final structure.

## SAFETY DOS AND DON'TS - ALWAYS

- 1 Always read and understand this guide before you begin assembly.
- 2 Always ensure that all safety requirements are met and that BRIDGE QUICK is the correct access solution for the task you wish to perform.
- 3 Always ensure that BRIDGE QUICK is assembled and dismantled by a qualified, competent person.
- 4 Always cordon off the work area creating a zone with a radius that is 1m greater than the total height of BRIDGE QUICK.
- 5 Always wear the correct Personal Protective Equipment for the task being performed. Gloves, steel toecap boots, a hard hat and suitable clothing must be worn by all persons.
- 6 Always tie back long hair and remove items of loose jewellery.
- 7 Always perform a full risk assessment prior to assembling or using BRIDGE QUICK and abide by your findings.
- 8 Always prevent access to unauthorised persons if you have no other option but to leave BRIDGE QUICK unattended and if this is not possible then BRIDGE QUICK must be dismantled.
- 9 Always make tools and materials required for the assembly of your BRIDGE QUICK are made available on site.
- 10 Always ensure you properly assess the risk/method if tools or materials are hoisted to the platform via a rope.
- 11 Always access platforms from within BRIDGE QUICK and via the 4 rung frames positioned at the platform's trap door end. Keep your feet in the middle of the rungs and grip the upper rungs with your hands.
- 12 Always erect BRIDGE QUICK on smooth level ground that is capable of supporting its own weight, the user and any tools or materials without subsidence and free of obstructions.
- 13 Always use your BRIDGE QUICK in accordance with the instructions contained within this assembly guide.
- 14 Always use your BRIDGE QUICK in accordance with National Regulations.
- 15 Always remove persons and loose materials from your BRIDGE QUICK before attempting to move it.

## SAFETY DOS AND DON'TS - NEVER

- 1 Never use BRIDGE QUICK if you don't understand something in this guide; please contact the supplier for advice.
- 2 Never assemble, use, move or dismantle BRIDGE QUICK if you are tired or unwell or if you are under the influence of alcohol or drugs.
- 3 Never use BRIDGE QUICK in adverse weather conditions which may endanger the user.
- 4 Never use in wind conditions of Beaufort Force 5 and above. Please be aware of the tunnel effect caused by buildings close to each other. Dismantle the BRIDGE QUICK if wind reaches Beaufort 6.
- 5 Never assemble or use BRIDGE QUICK near overhead hazards such as power lines that are within reach of BRIDGE QUICK or the user.
- 6 Never ascend or descend your BRIDGE QUICK if both hands are not free.
- 7 Never add banners, notice boards, etc. to BRIDGE QUICK or suspend weights from the tower.
- 8 Never use MITOWER if contaminated by paint, chemicals, etc.
- 9 Never overload the platforms (see page 2 for details).
- 10 Never suspend BRIDGE QUICK from another structure.
- 11 Never lean from BRIDGE QUICK and never apply undue side force (max 200N)
- 12 Never stand on the guardrails, toe boards, boxes (or similar) to gain extra height. If the working height is insufficient either construct BRIDGE QUICK to the required height or use an alternative method.
- 13 Never use damaged components in your BRIDGE QUICK assembly.
- 14 Never use more than one working platform in your BRIDGE QUICK.
- 15 Never allow more than one person on a working platform.
- 16 Never use BRIDGE QUICK as a means to enter or exit other structures, or as a means of edge protection.
- 17 Never exceed a distance between platforms of 2.0m except for the first platform which can be 3.4m from the ground.
- 18 Never stand on an unguarded platform.
- 19 Never move the tower with people or materials on it.
- 20 Never lift the tower with mechanical equipment.
- 21 Never climb the outside of the tower.

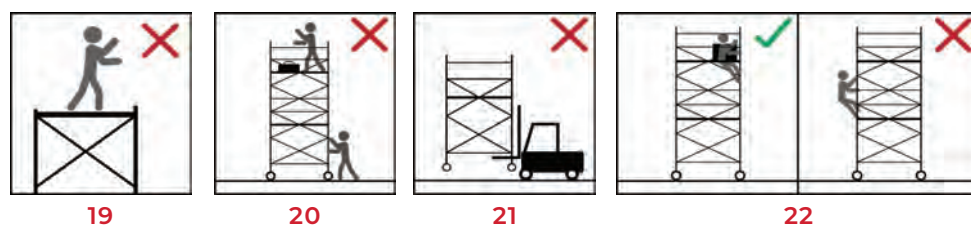
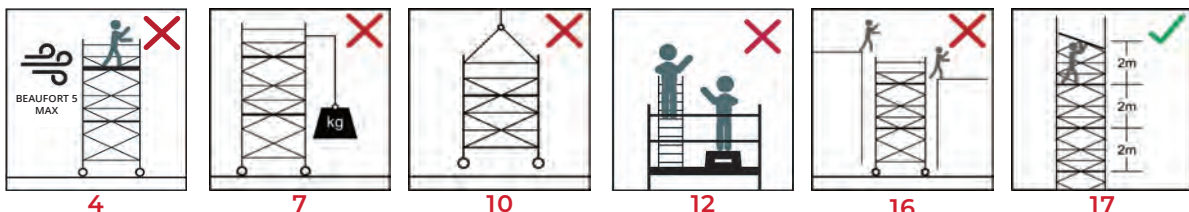

# BEFORE YOU START

## PREPARATION

The floor area must be clear of any obstructions including materials and debris. Check that you have all the components necessary to construct the tower height you require. Check also each component for condition and correct function. If any part is missing or damaged/not working correctly it must be replaced before assembling. Assess the height of tower required before attempting assembly. Refer to component matrices on page 7 for the correct component quantities and if required, stabilisers or ballast for the chosen platform height. Please note working height is generally calculated as two meters above platform height.

## 3T (THROUGH THE TRAPDOOR) SYSTEM

The 3T method of construction has been developed to reduce the risk of an erector falling from a tower during construction. The erector must sit on the platform with legs through the hatch and feet on the frame rungs when attaching handrail braces above the platform. This ensures the erector is always protected by a set of handrail braces.

## TYING IN

You should consider tying in the tower to add stability, but this may only be carried out by a suitably trained person.

## BALLAST

**Where shown** in the component matrices, ballast must be used to stabilise against overturning. Only use solid materials as ballast (i.e. no loose materials) and position to avoid overloading individual components. Ballast should be attached to the horizontal rungs of your BRIDGE QUICK and be either securely fastened or be of a design to prevent accidental removal. An example of such ballast is shown below. The quantity of ballast is shown in the component matrices on page 7.

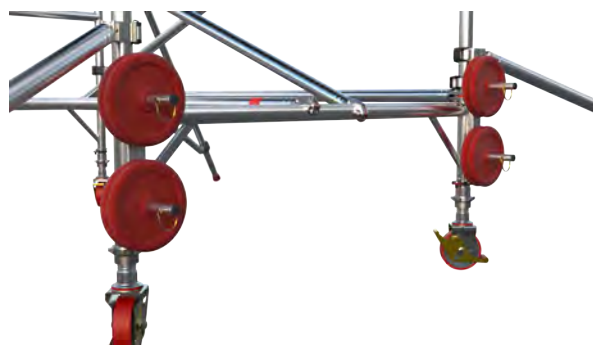

## ASSEMBLY GUIDE

These instructions must always be made available to the user. If replacement copies are required, please contact your supplier. This assembly guide is to be made available on the location of use of this BRIDGE QUICK.

## DAMAGED COMPONENTS

Regularly inspect all components for damage. Damaged components must be quarantined so that they cannot be used. Where safe to do so, the component can be repaired but only by a qualified repairer. If in doubt contact your supplier for advice.

## DISMANTLING YOUR BRIDGE QUICK

BRIDGE QUICK is easily dismantled by simply reversing the erection procedure. You must, however, be protected by handrail braces when standing on any platform and ensure that you use the 3T method when removing handrail braces.

## AFTER ASSEMBLY

After assembly the following information needs to be displayed on the access tower and should be clearly visible from the ground (e.g. on a Scafftag).

- The name & contact details of the responsible person
- If the tower is ready for application or not.
- The load class and Uniformly Distributed Load.
- If the access tower is intended for indoor use only.
- The date of assembly.

# GETTING STARTED

## GETTING STARTED

The Bridge Quick is available in 2.5m length platforms and single width tower sections, with a bridging beam section capable of carrying three bridging platforms. It is assumed the first and second towers have been erected according to the relevant instruction manual and the build process shown overleaf starts from this position. Instruction manuals can be found at <https://www.popupproducts.co.uk/types/guides/> or hard copies can be supplied by your tower supplier.

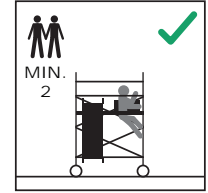

Bridge Quick requires a minimum of two persons to assemble it. Do not attempt to assemble Bridge Quick on your own.

## STABILISERS

Stabilisers are supplied and must be fitted when erecting the first and second tower structures. Please refer to the component matrices within the instruction manuals relevant to erecting the first and second towers for more details.

Normally once the Bridge Quick structure has been completed, the stabilisers used during the erection of the structure can be removed. However in some instances the use of stabilisers or ballast might be required. Please refer to the component matrices on page 6 for further details.

If used, stabilisers should be placed as shown in the diagrams below.

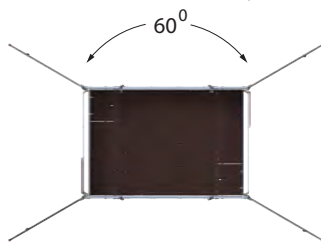

Fig. 1

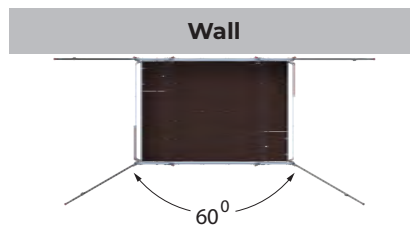

Fig. 2

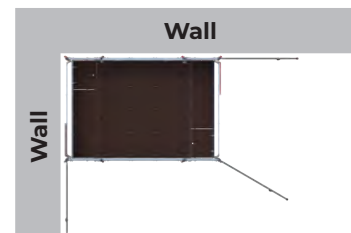

Fig. 3

## MOVING YOUR BRIDGE QUICK

When your BRIDGE QUICK needs to be moved a small distance to enable you to continue your task, this can be achieved provided the stabilisers, if required, can remain in pattern and all tools, materials and personnel are removed from the tower.

Assess the route of travel, avoiding overhead obstacles such as power lines before moving your BRIDGE QUICK. You will need to raise the stabilisers, if attached, so that they are no more than 25mm above the floor and properly locked.

You must only move BRIDGE QUICK by manual effort, at a slow pace and only after fully assessing the risk. Once moved, always check BRIDGE QUICK before using ensuring it is level within the inclination of 1% before using it.

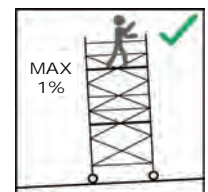

If BRIDGE QUICK is to be moved to a new location, a new level or over rough terrain, it must be fully dismantled and rebuilt at the new location. Your BRIDGE QUICK is only to be moved on flat obstacle free solid ground (0% Slope).

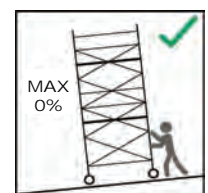

# BRIDGE QUICK SQ AGR ASSEMBLY GUIDE

SINGLE WIDTH 850 TOWERS 4.2M PLATFORM HEIGHT

## BUILD PROCESS

### STEP 1

Move tower one and two together to a distance where the 2.1m link braces can be placed on top of the second rung of each tower, hooks facing outwards as shown. The stabilisers of both towers might need to be adjusted to enable the towers to be placed at the appropriate distance to attach the 2.1m braces.

It is advisable to keep the stabilisers attached to the two towers during the building of the Bridge Quick structure. They can be removed once the structure has been completed unless required as per component matrices on page 7.

Level around base of tower using spirit level, making adjustments as necessary to adjustable legs until the frames have an inclination no more than 1% from the vertical.

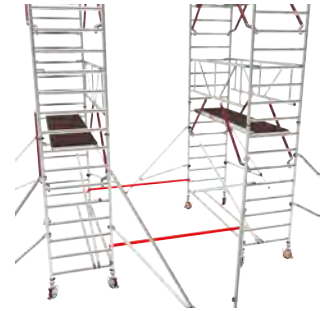

### STEP 2

Climb the towers and access the upper platforms. Attach four upper link braces to either side of the tower. One pair should be attached on top of the eighteenth rungs of the towers and the second pair to the twentieth rungs.

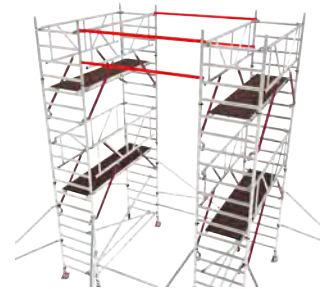

### STEP 3

Attach a pair of 2.5m horizontal braces onto the eighteenth and twentieth rungs, hooks facing downwards, on both towers. Ensure the braces are positioned inboard of the SQ AGR panels. This will aid the removal of the panels in the next step.

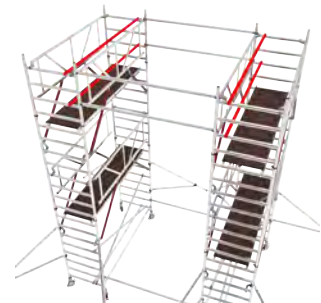

### STEP 4

Descend to the platform on the eighth rung and remove both inner SQ AGR panels from the twentieth rungs. Fold the arms away on both panels and clip onto the inner fourth rungs of each tower for safe keeping. Attach a bridging beam to either side of the towers, placing the lower hooks on the thirteenth rungs of both towers, engage the upper hooks ensuring they are positively locked onto the end frame vertical tubes.

The upper hooks must face outwards.

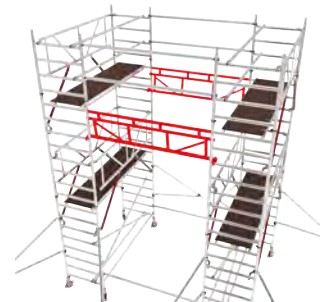

### STEP 5

Place two infill platforms onto the bridging beams, ensuring the platforms butt up against the upper platforms of both towers as shown.

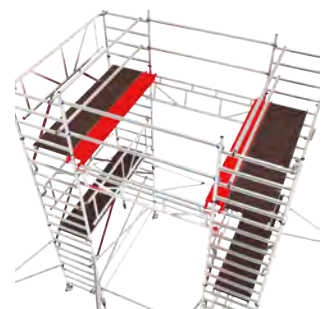

# BRIDGE QUICK SQ AGR ASSEMBLY GUIDE

SINGLE WIDTH 850 TOWERS 4.2M PLATFORM HEIGHT

## BUILD PROCESS

### STEP 6

From the upper platforms of the towers place two Fiber-deck® bridging platforms onto the bridging beam as shown.

This must be carried out from behind the guardrails. Do not attempt to go past the guardrails whilst positioning the Fiber-deck® bridging platforms.

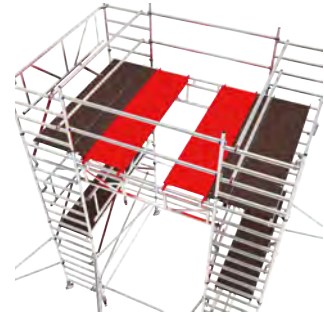

### STEP 7

Push the Fiber-deck® bridging platform towards the centre of the bridging beam as far as possible without moving past the guardrails.

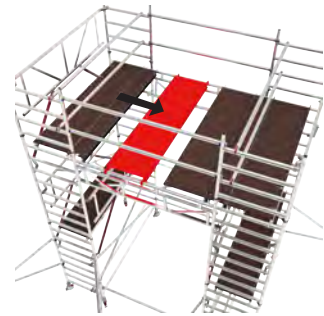

### STEP 8

Place the third Fiber-deck® bridging platform onto the bridging beam and push the second Fiber-deck® bridging platform along the bridging beam. Finally drop the platform into place as shown.

Minor adjustments of all platforms might be required to ensure all platforms are butted up against each other and hooks are engaged fully with either the bridging beam or tower end frame horizontal rungs.

Remove the four 2.5m handrail braces and attach to the inner fourth rungs of both towers next to the AGR panels for safe keeping.

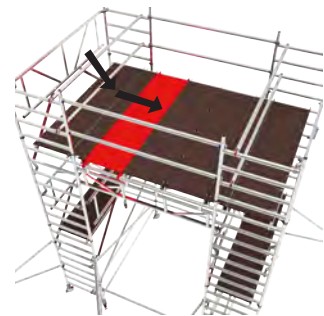

### STEP 9

Unfold and assemble the two toeboard sections, using the locking pins to connect the two sections together.

Place the toeboard around all platforms ensuring the lower surface of the toeboard sections are sitting on the upper surface of the platform hooks.

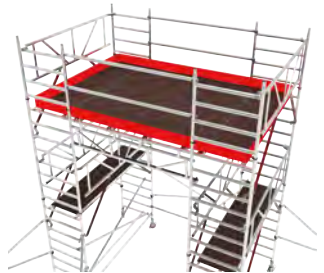

### STEP 10

Climb down the towers and proceed to remove the stabilisers if not required.

Refer to page 7 for component and ballast information on each platform height.

Carry out the 10 point pre-use checklist found on page 13.

Disassembly is simply a reversal of this build method.



# 10 POINT PRE-USE SAFETY CHECKLIST

## 10 POINT PRE-USE CHECKLIST FOR USERS

1	BEFORE USE	Ensure structure is correct, complete and level.
2	COMPONENTS	Check all components are free from damage.
3	CASTORS	Ensure they are locked.
4	ENVIRONMENT	No environmental changes have influenced the safe use of your Bridge Quick.
5	STABILISER COUPLER CLAMPS	Check they are secure & correctly attached.
6	GUARDRAILS	Make sure all platforms are fully enclosed by guardrails.
7	BRACE CLAWS	Check they are locked correctly.
8	WINDLOCK CATCHES	Make sure they are engaged.
9	FRAME CLIPS	Make sure they are engaged.
10	TOE BOARDS	Check they are correctly positioned on the platform.

**REGISTRATIONS**

**ISO 9001**

**EN 1004  
Class 3**

**BS 1139  
Compliant**





**MEP Hire**

Mechanical, Electrical & Low Level Access Specialists